



	MATH (week-31)
Monday	2 Ten frames, counters that fit in the ten frames, Math Notebook, a plain sheet of paper, a pencil and an eraser.
Tuesday	
Wednesday	2 Ten frames, counters that fit in the ten frames, Math Notebook & Course book, a plain sheet of paper, a pencil and an eraser.
Thursday	
Friday	2 Ten frames, counters that fit in the ten frames, a plain sheet of paper, Math Notebook & Course book, a pencil and an eraser.

	ENGLISH (week-31)
Monday	
Tuesday	English note book.
Wednesday	En_21 & English note book.
	
Thursday	
Friday	En_18
	

ARABI (week-31)	
Monday	
Tuesday	درس ج \Pencil\Eraser\4 liner notebook of Arabi
Wednesday	
Thursday	درس ج \Pencil\Eraser\4 liner notebook of Arabi
Friday	درس ج \Pencil\Eraser\4 liner notebook of Arabi

DIRASAT (week-31)	
Monday	an A4 size blank paper crayons
Tuesday	
Wednesday	

1. A cardboard box with a lid-A4 paper boxes or shoe boxes are ideal.

2. A Torch

3. Small objects like- small toys, any small object which can be put in standing position in the box

Thursday

Use a craft knife to make a flap in the lid about 3cm x 3cm. Use a sharp point to make a tiny hole in the side at centre. This hole needs to be small to prevent light getting in. A circular hole-smaller than the diameter of the pencil.

Kindly make sure that - you can place small objects from the upper flap into the box, also after placing the object the upper flap should be well covered so no light can enter through it.

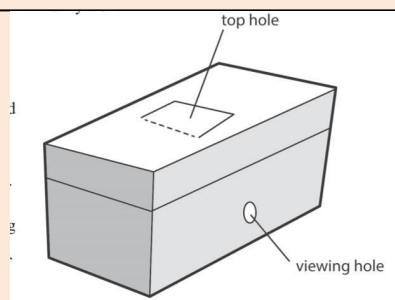

SPORTS (week-31)

Thursday

A football .